

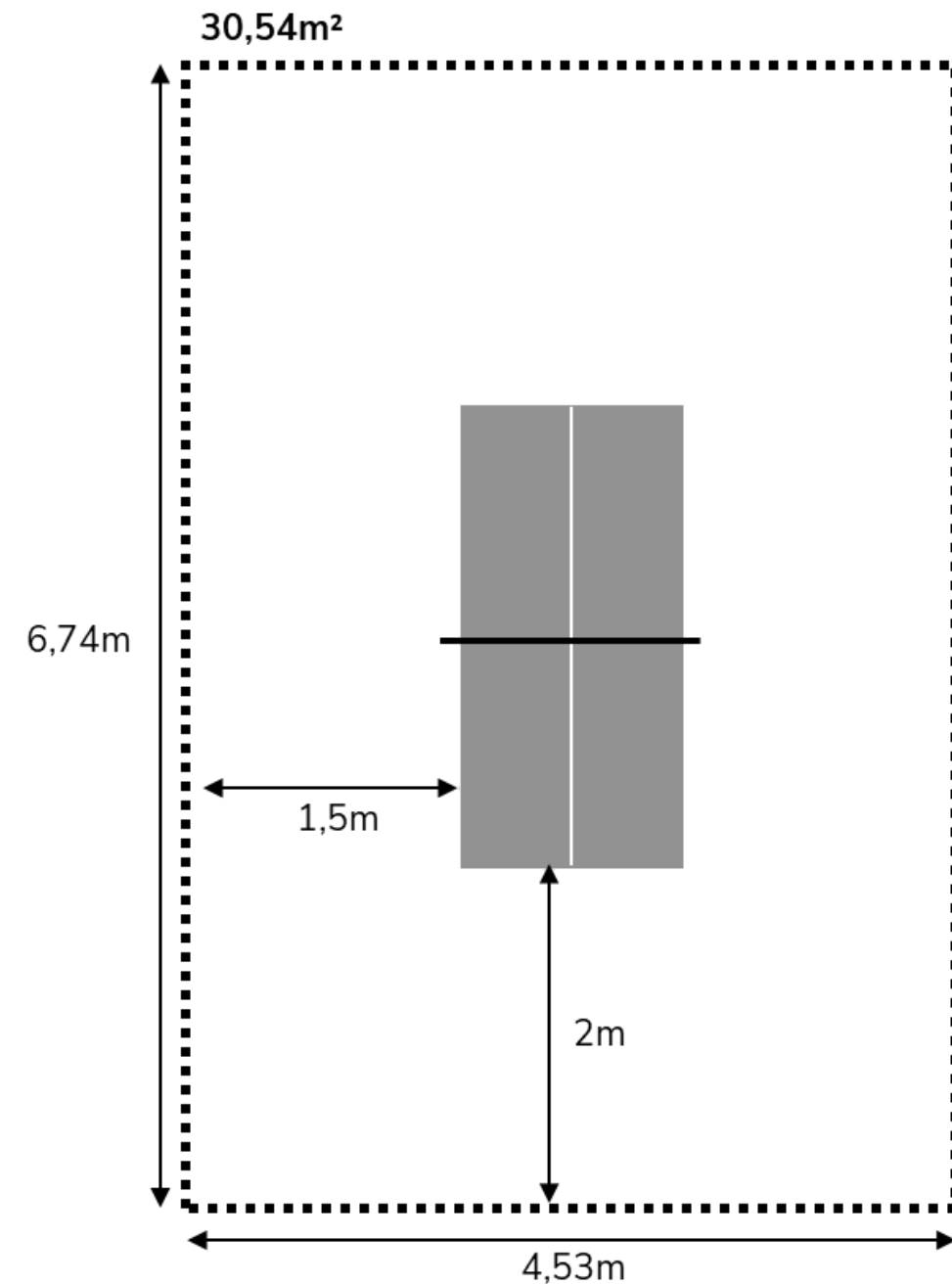

LES PLANS DES ESPACES PING EXTERIEUR

AIRE DE JEU CONSEILLÉE



Pour chaque table, une aire de 30,54m² minimum permettra d'assurer le confort et la sécurité nécessaires aux pratiquants. Ces dimensions respectent également la norme "Équipement sportif de plein air en accès libre" (NFS 52-901).

Détail des dimensions :

- 2m de recul minimum (distance entre la table et la limite de l'aire de jeu) ;
- 1,5m de séparation latérale (distance entre la table et la limite de l'aire de jeu).

L'ESPACE 2 TABLES

Option 1

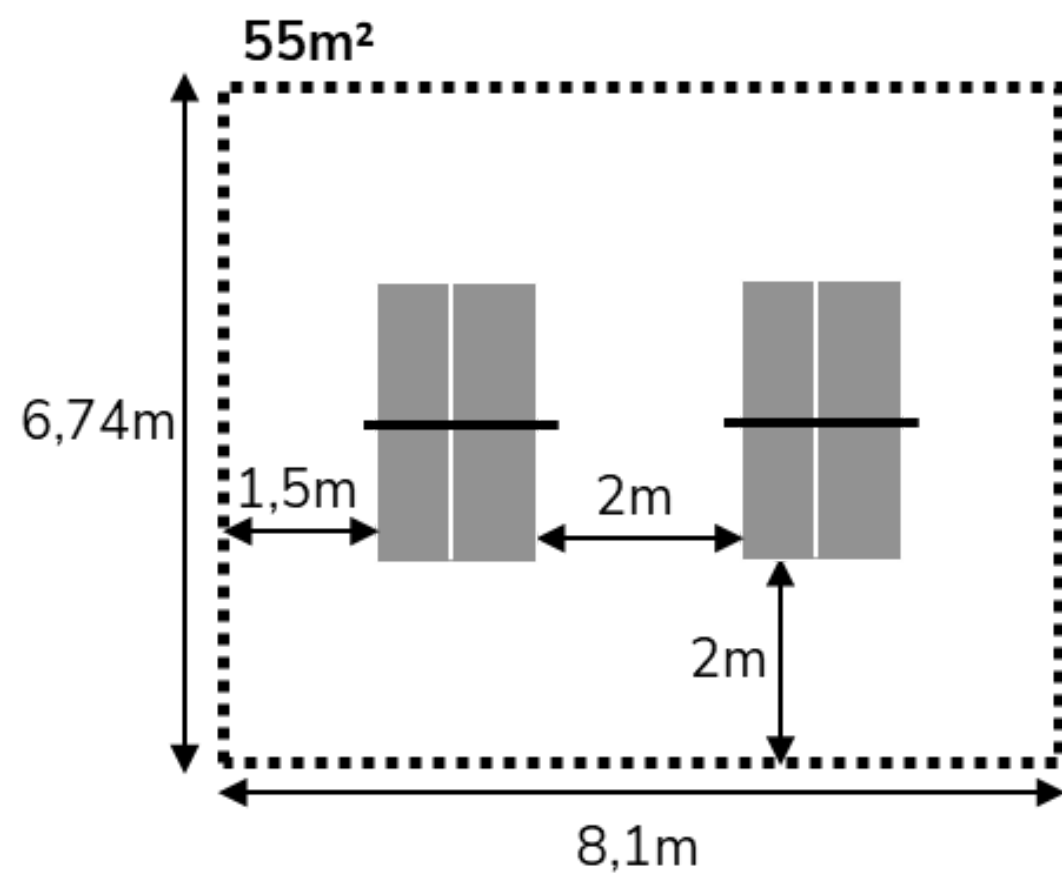

Option 2

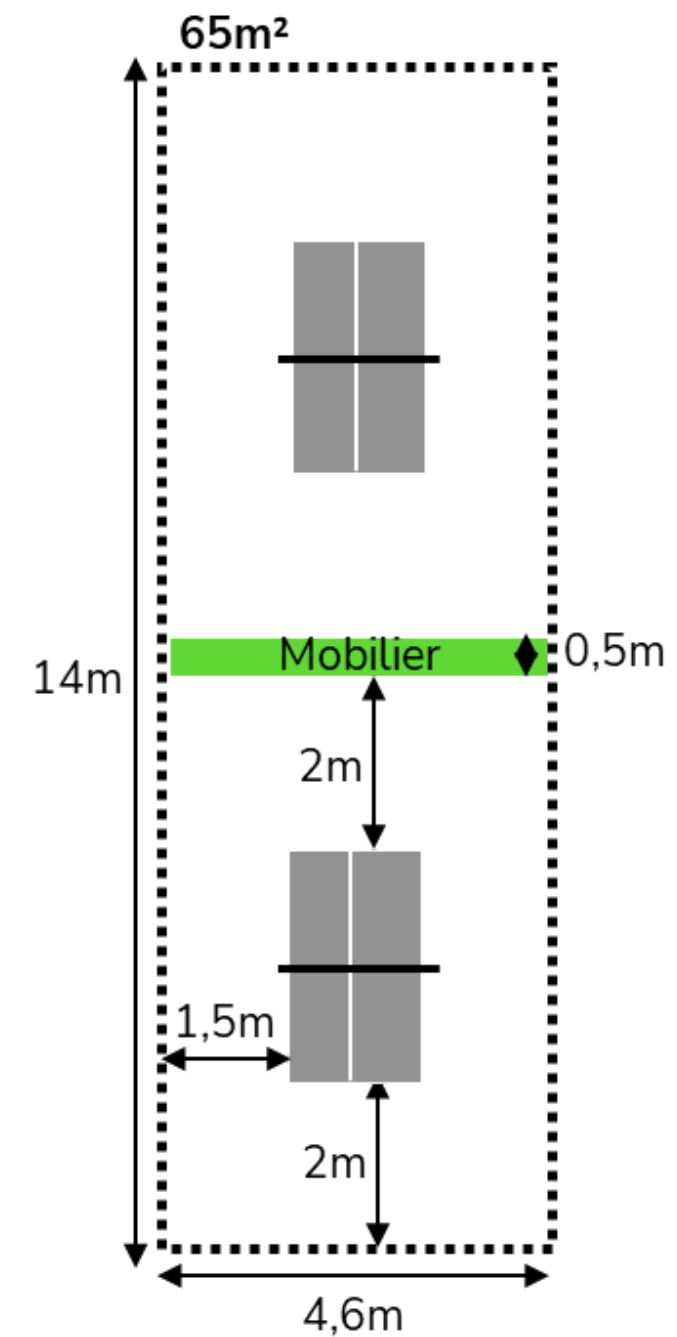

L'ESPACE 3 TABLES

Option 1

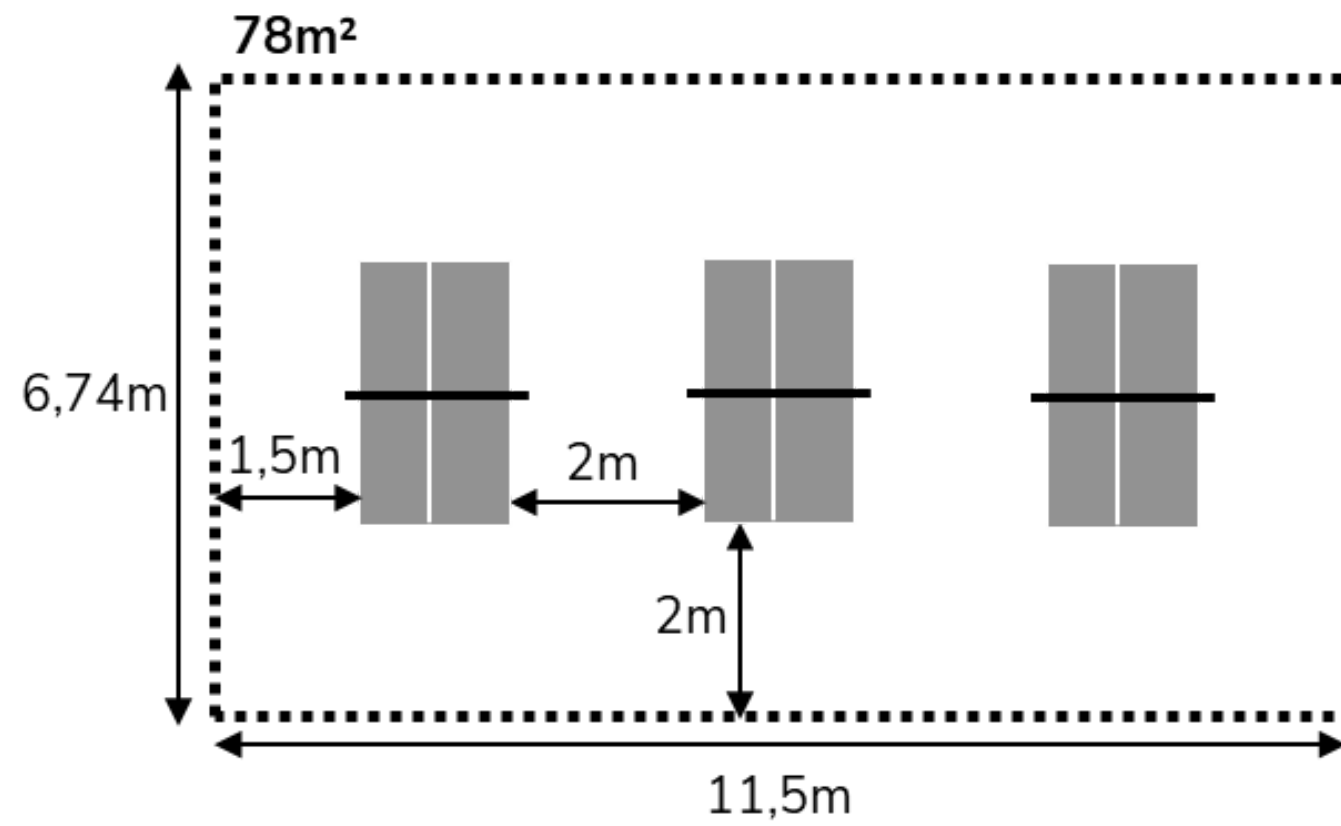

Option 2

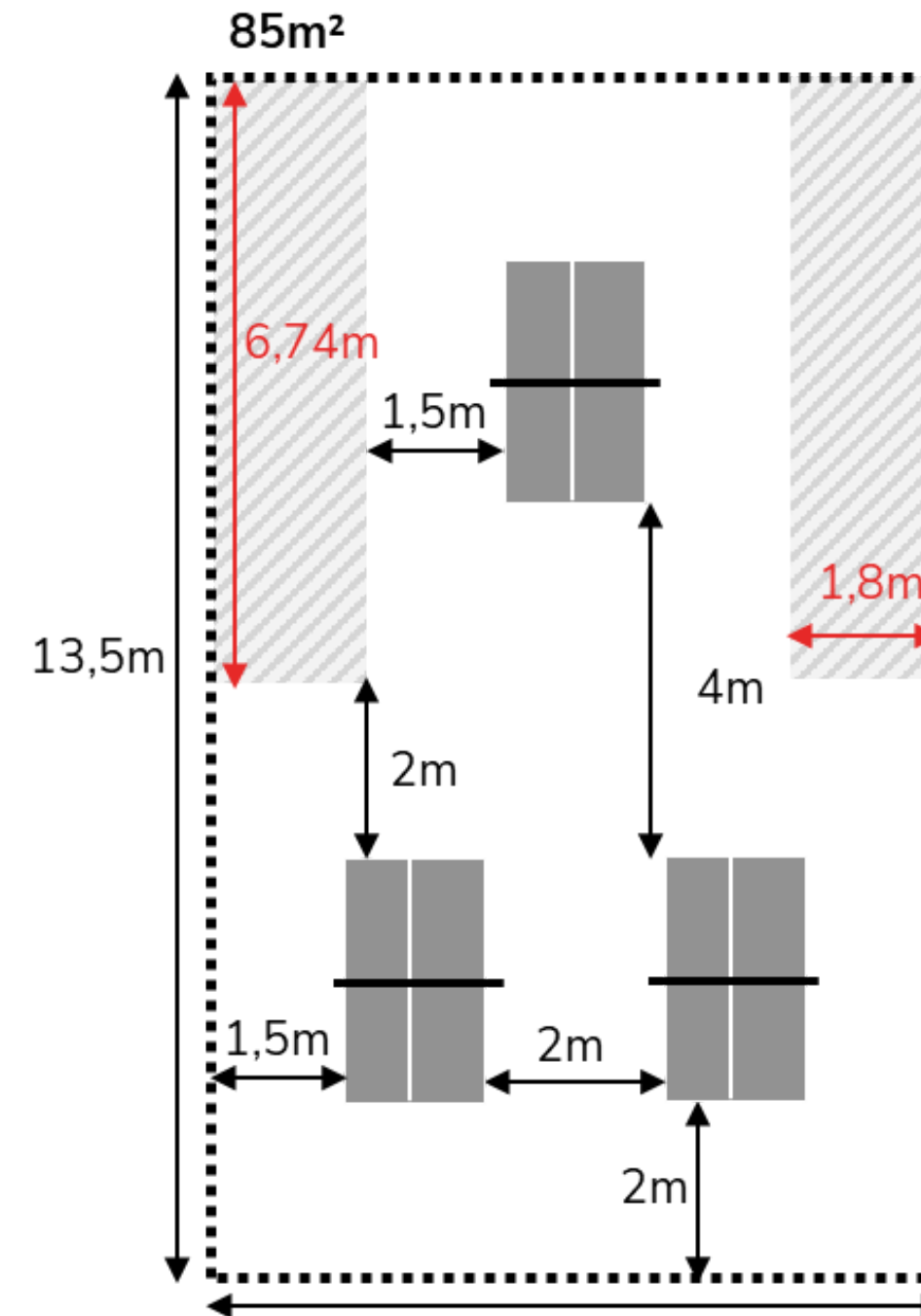

 Espace disponible

L'ESPACE 4 TABLES

Option 1

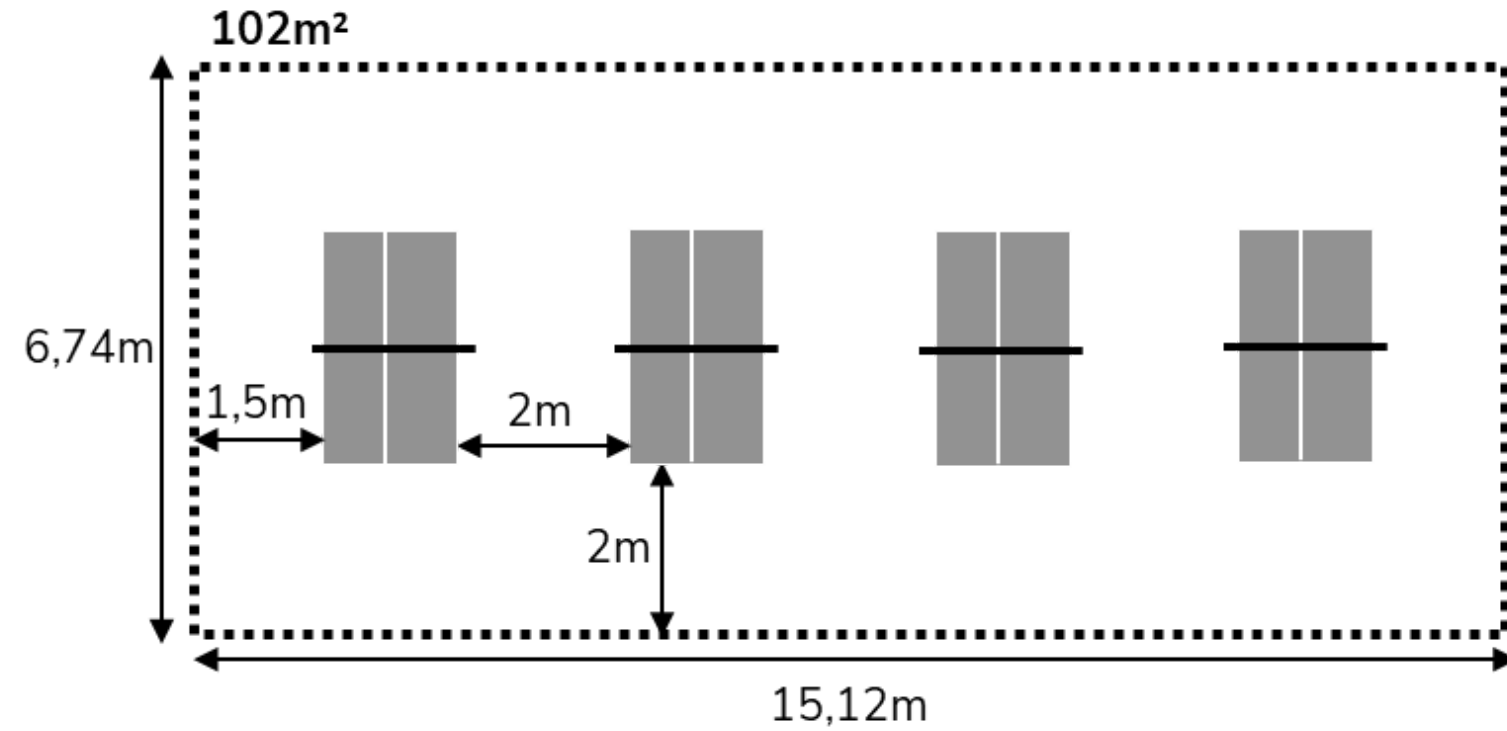

Option 2

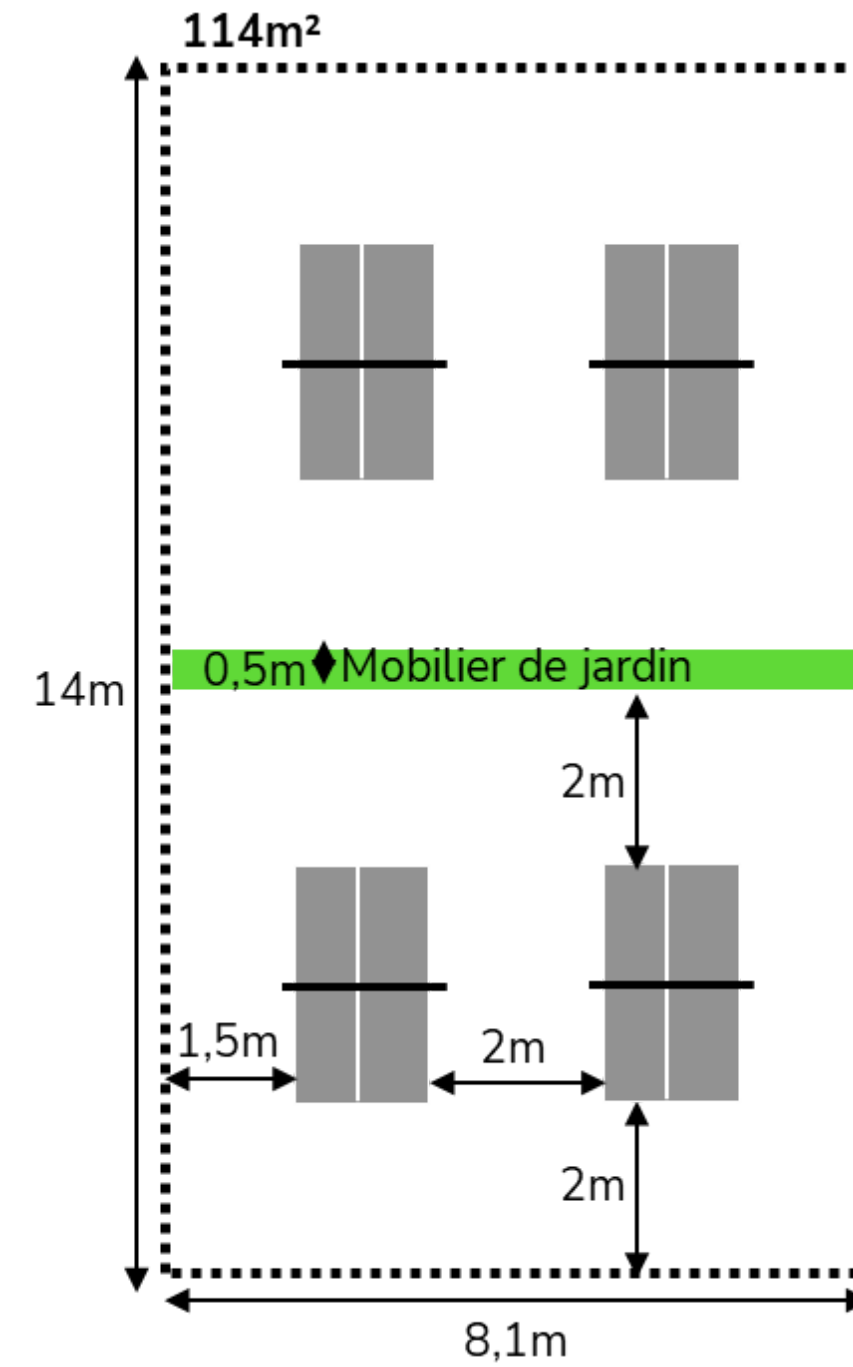

L'ESPACE 5 TABLES

Option 1

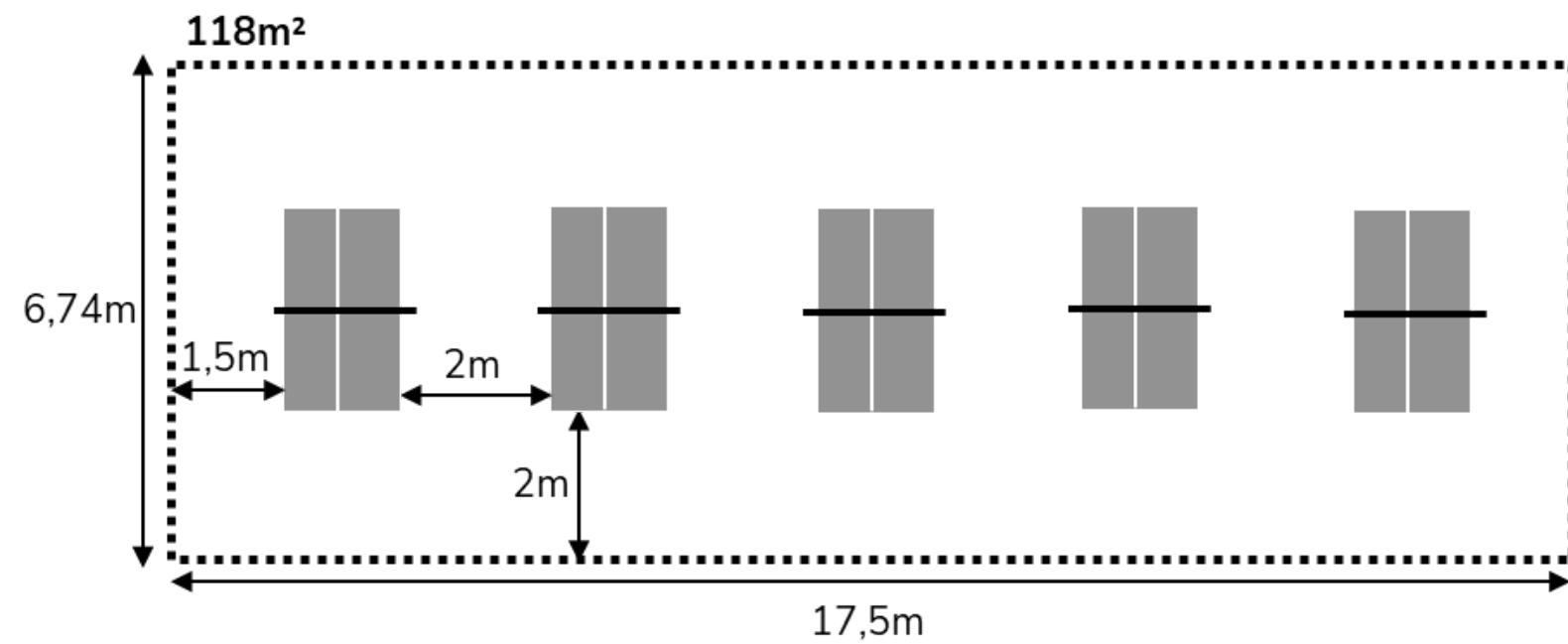

Option 2

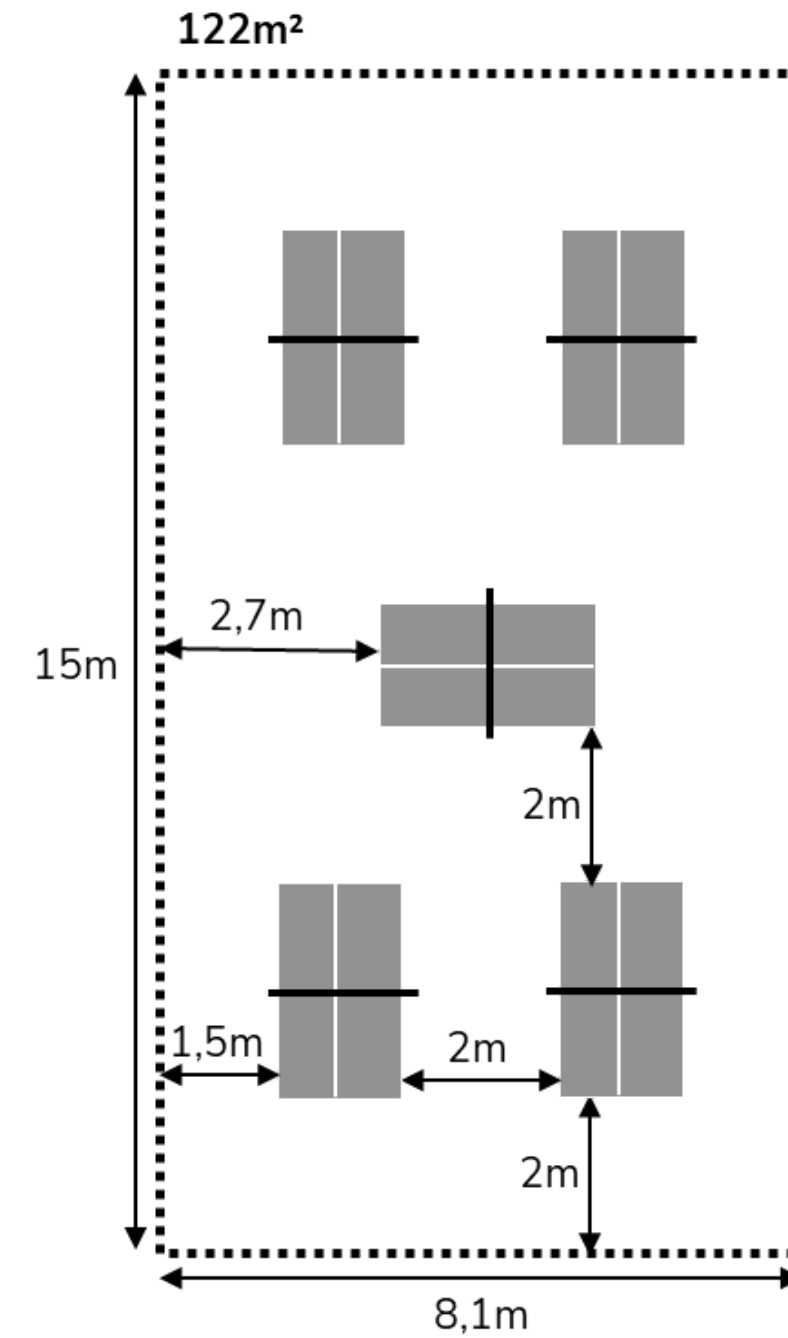

L'ESPACE 6 TABLES

Option 1

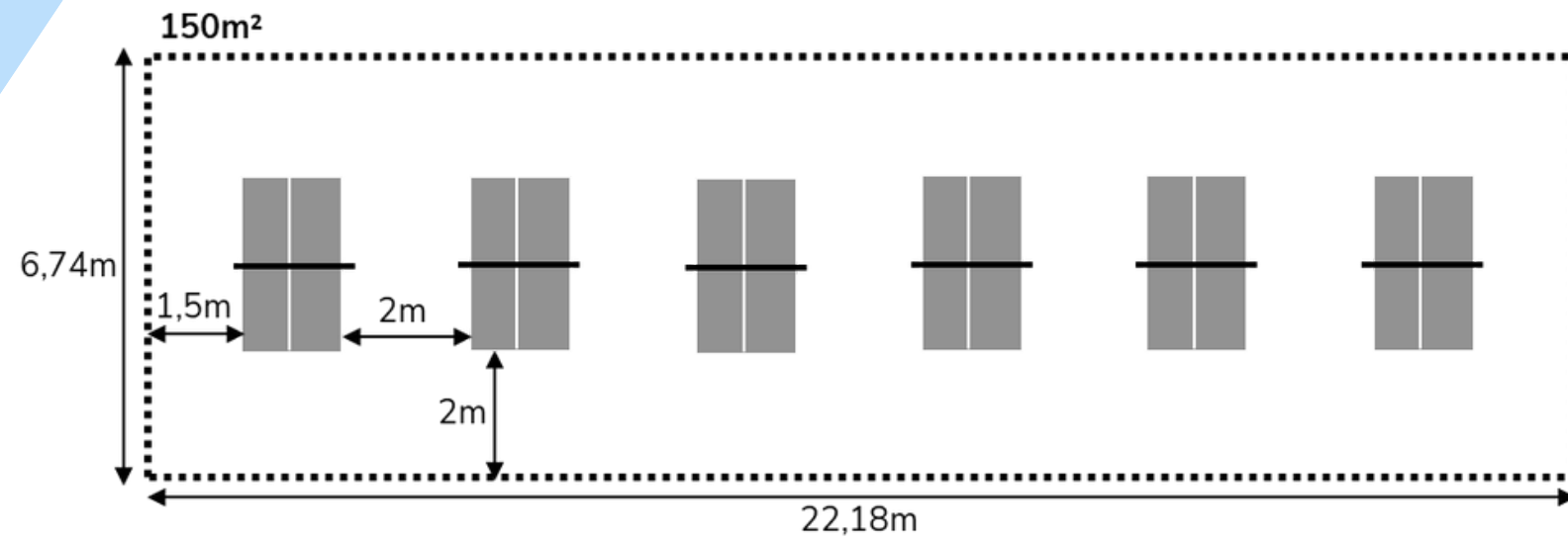

Option 2

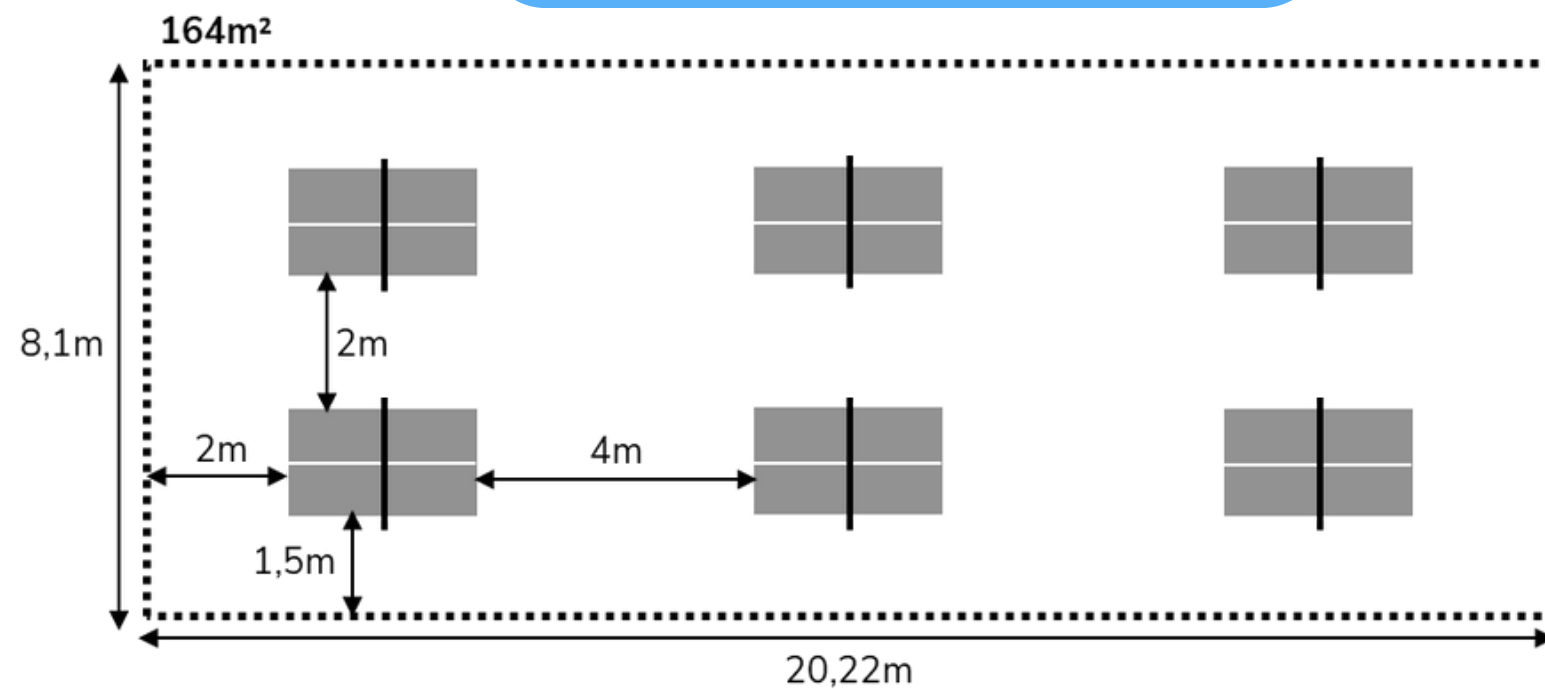

Option 3

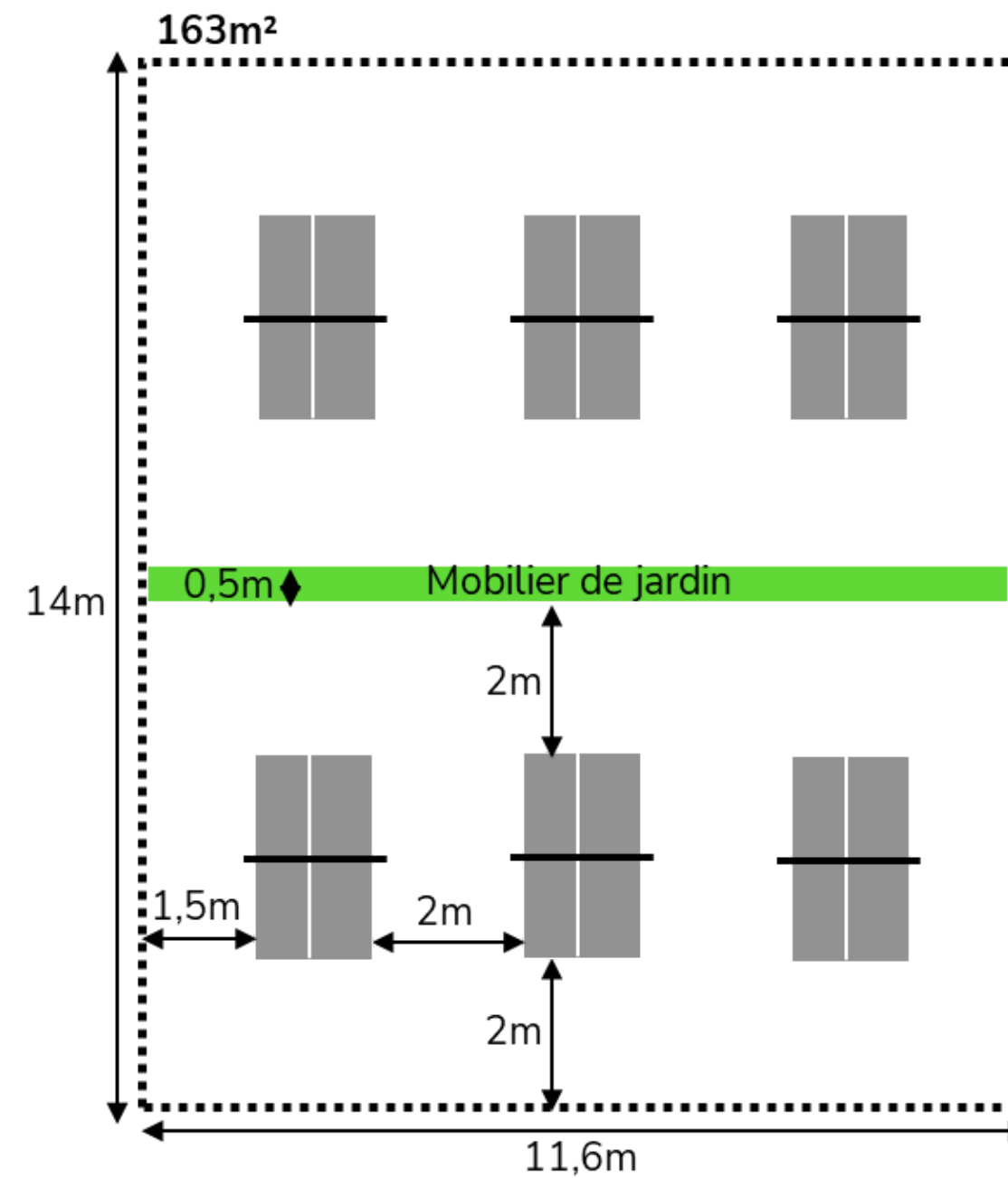

L'ESPACE 8 TABLES

Option 1

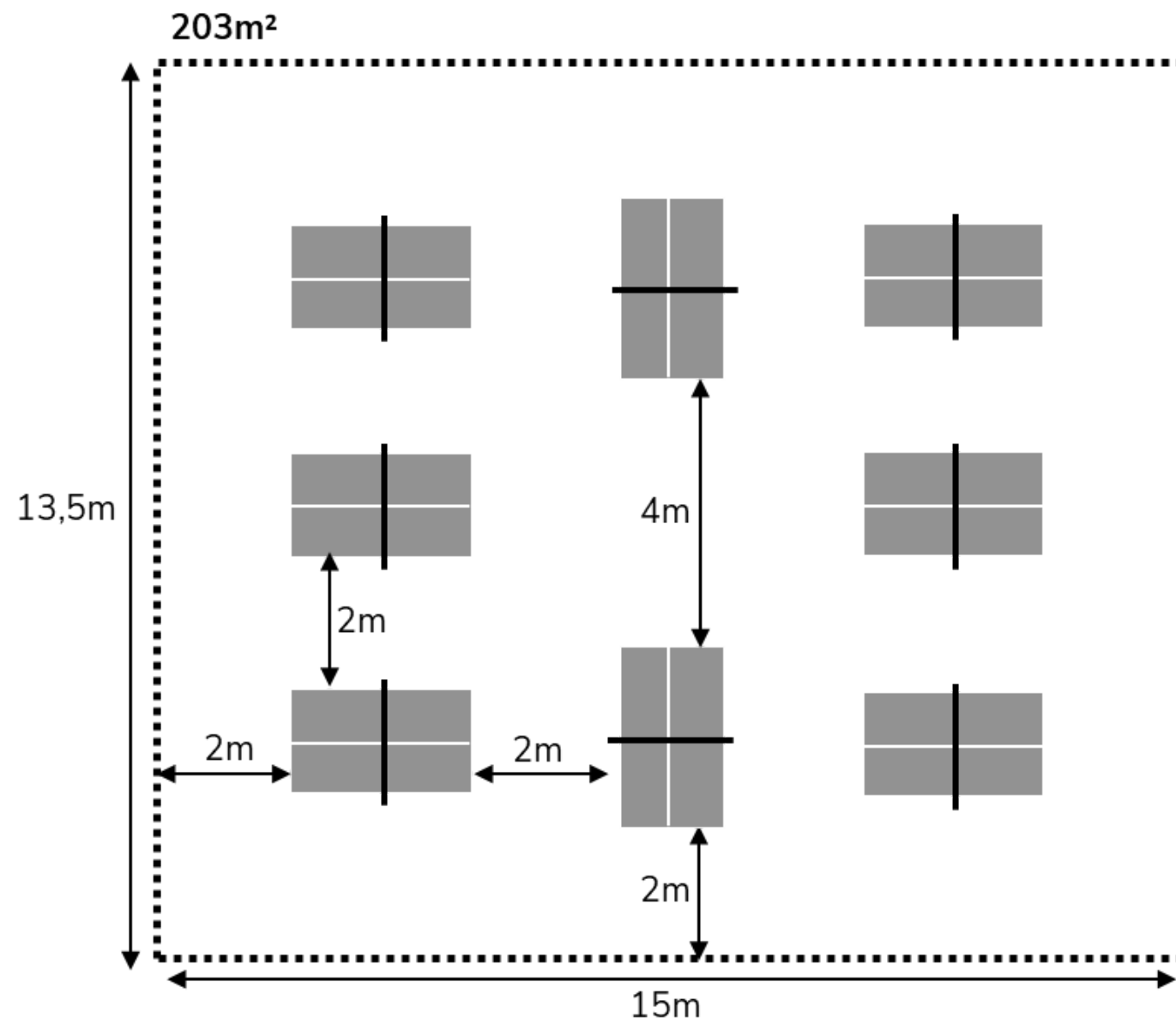

Option 2

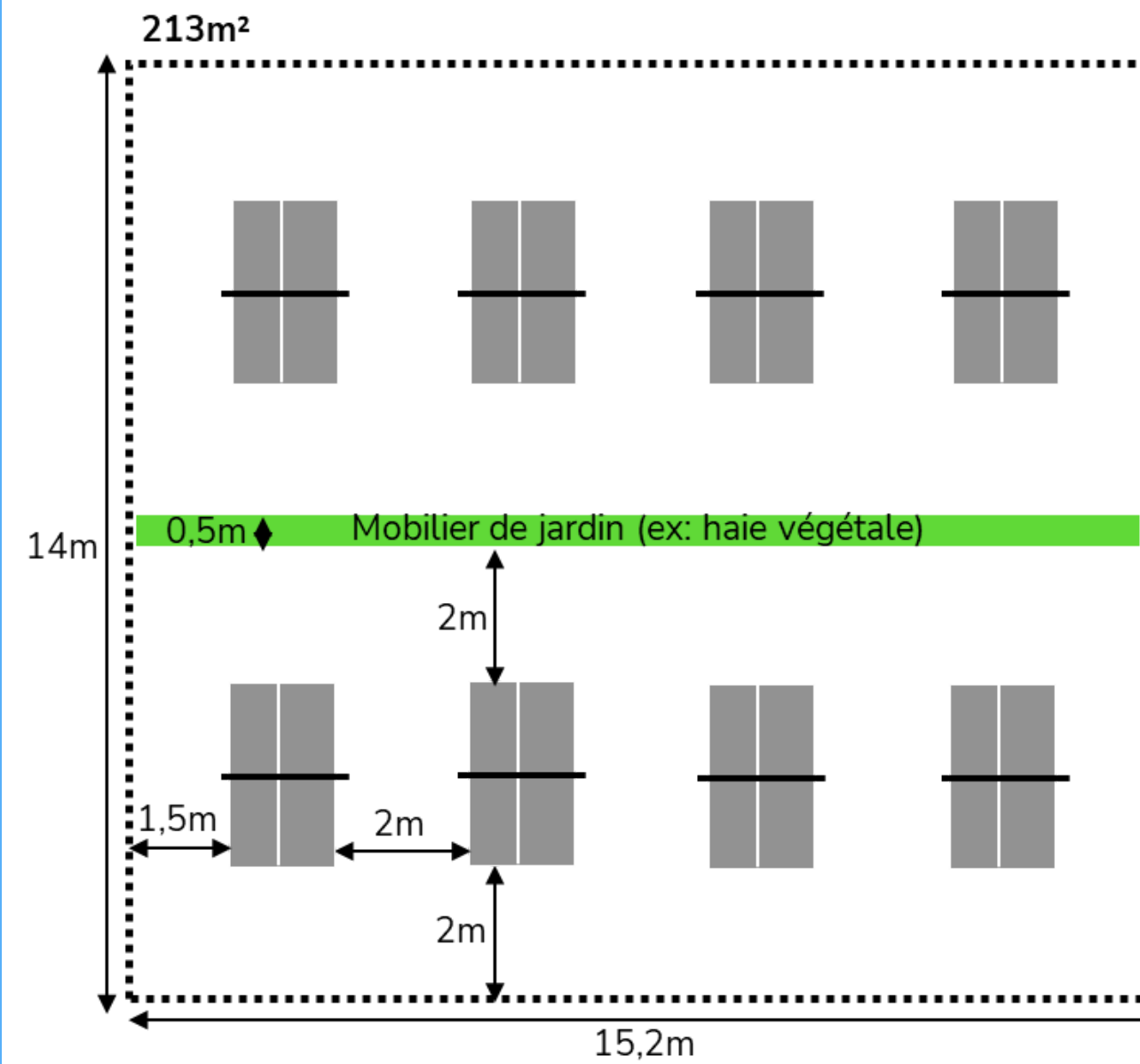

L'ESPACE 10 TABLES

Option 1

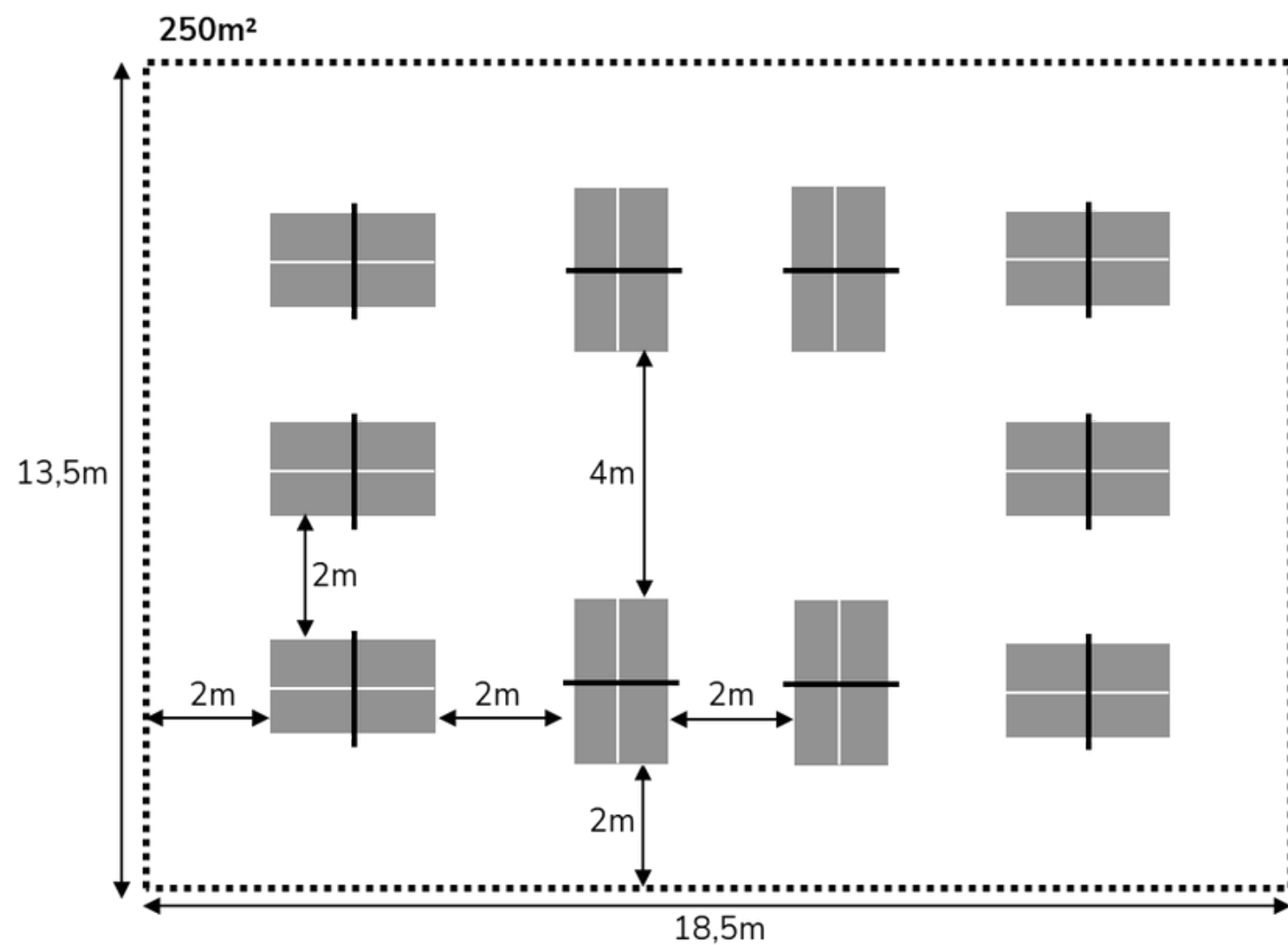

Option 2

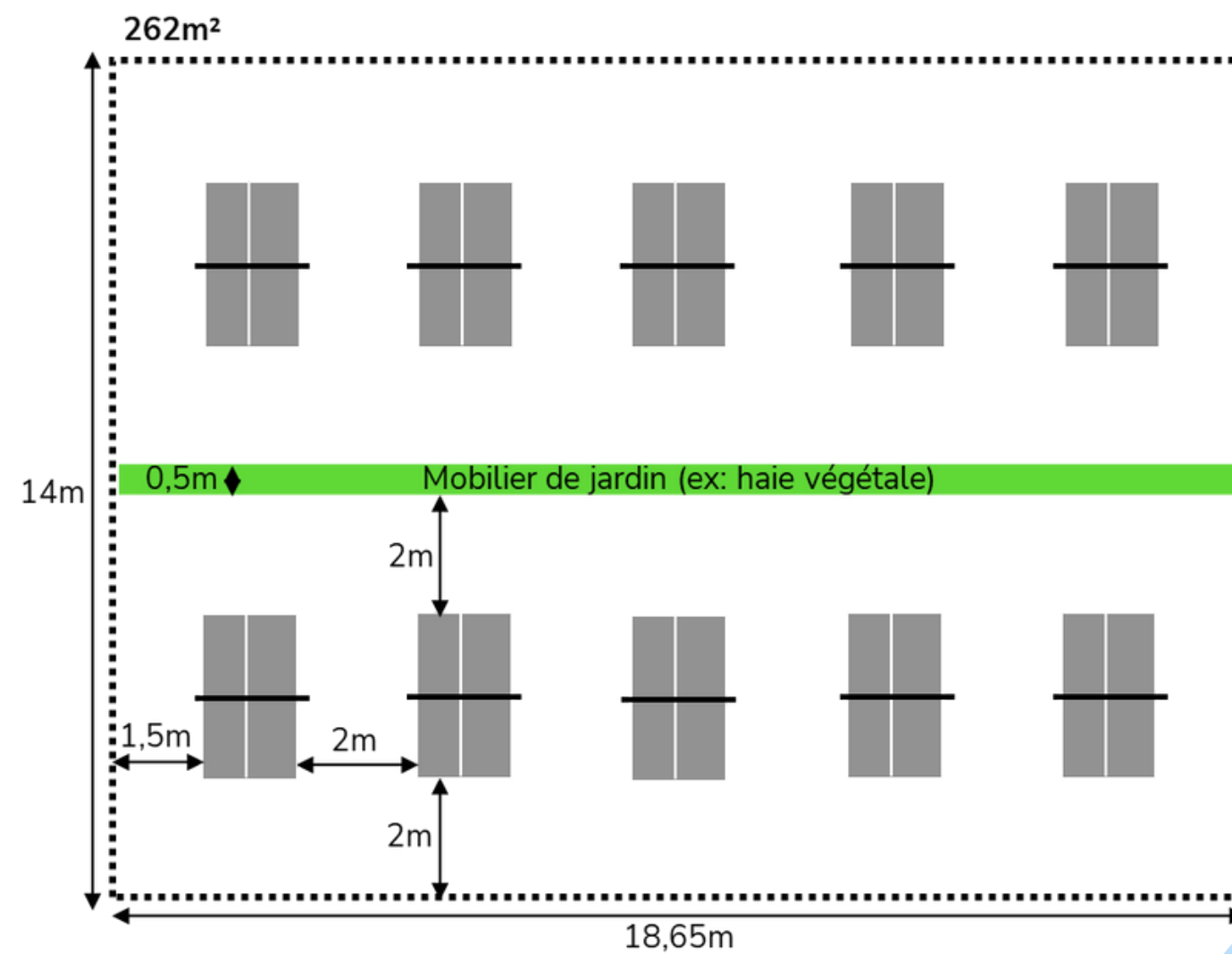



POUR ALLER PLUS LOIN

Contactez la Fédération Française de tennis de table, via son chargé de mission Ping extérieur !



MAXIME DELHOMME



Chargé de mission Ping extérieur



01 53 94 50 20



maxime.delhomme@fftt.org

